

HSDR

Submersible Drain pump

| | | |
|--------------------------|----------------------|---------|
| Standard Material | Casing | GC200 |
| | Shaft | STS304 |
| | Impeller | GC200 |
| | M/C Seal | SIC/SIC |
| | Lifting chain | NOMAL |



Applications

High head and low capacity
Drainage for factory, building and sanitary facility

Features

- Less clogging by semi-open impeller
- Double mechanical seal for tightening waterproof
- 2pole motor for better efficiency at high head
- Easier maintenance with automatic discharge connector

Performance Curves

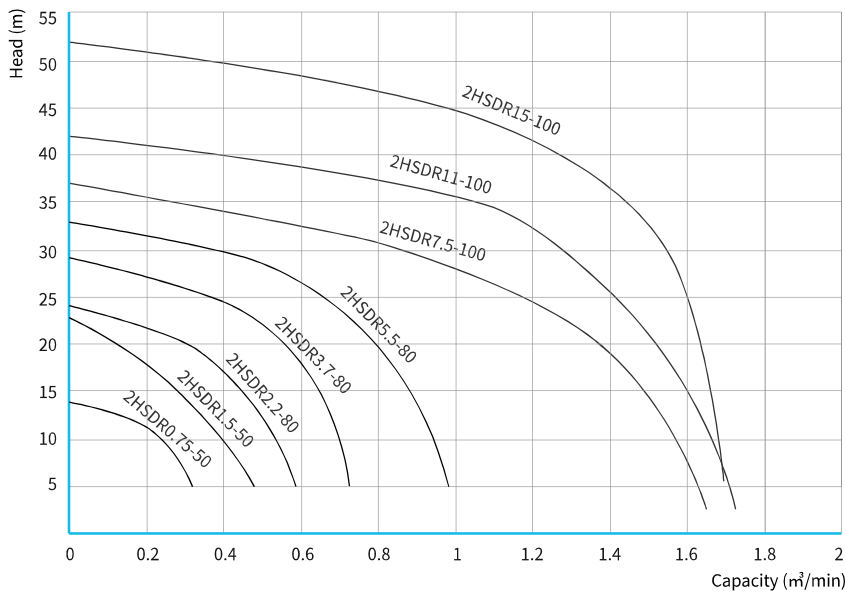

Outline Drawing

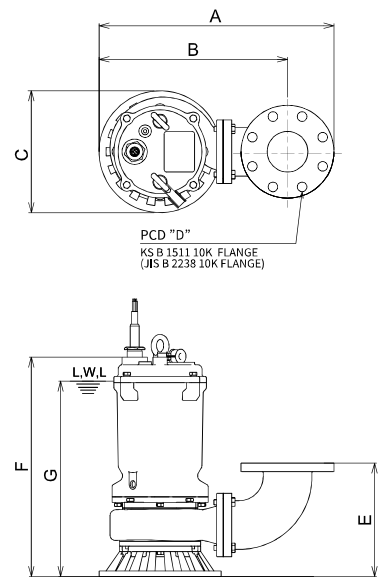

| Model | Power | Pole | Output (kW) | Discharge (mm) | Head (m) | Capacity (m³/min) | Dimensions | | | | | | |
|--------------|-------------------------------|------|-------------|----------------|----------|-------------------|------------|-----|-----|-----|-----|-----|-----|
| | | | | | | | A | B | C | D | E | F | G |
| 2HSDR0.75-50 | three phase / 380V 415V | 2P | 0.75 | 50 | 12 | 0.16 | 405 | 325 | 220 | 120 | 170 | 370 | 320 |
| 2HSDR1.5-50 | | | 15 | | 0.25 | 430 | 350 | 250 | 120 | 200 | 430 | 370 | |
| 2HSDR2.2-80 | | | 2.2 | 80 | 20 | 0.3 | 470 | 380 | 250 | 150 | 220 | 450 | 385 |
| 2HSDR3.7-80 | | | 3.7 | | 20 | 0.5 | 475 | 380 | 250 | 150 | 230 | 500 | 430 |
| 2HSDR5.5-80 | | | 5.5 | | 25 | 0.6 | 510 | 420 | 255 | 150 | 240 | 540 | 485 |
| 2HSDR7.5-100 | | | 7.5 | 100 | 30 | 0.8 | 560 | 455 | 260 | 175 | 265 | 645 | 545 |
| 2HSDR11-100 | | | 11 | | 35 | 1 | 640 | 535 | 360 | 175 | 295 | 925 | 705 |
| 2HSDR15-100 | | | 15 | | 40 | 1.2 | 640 | 535 | 360 | 175 | 295 | 925 | 705 |

* The above dimensions might be changed without further notification.
* Please contact us regarding automatic discharge connector.